

3 Burners With Side Searing Burner LP Grill

ITM. / ART. 215748

Model: 780-0862SB

Care & Assembly Instructions

IMPORTANT, RETAIN FOR FUTURE REFERENCE: READ CAREFULLY

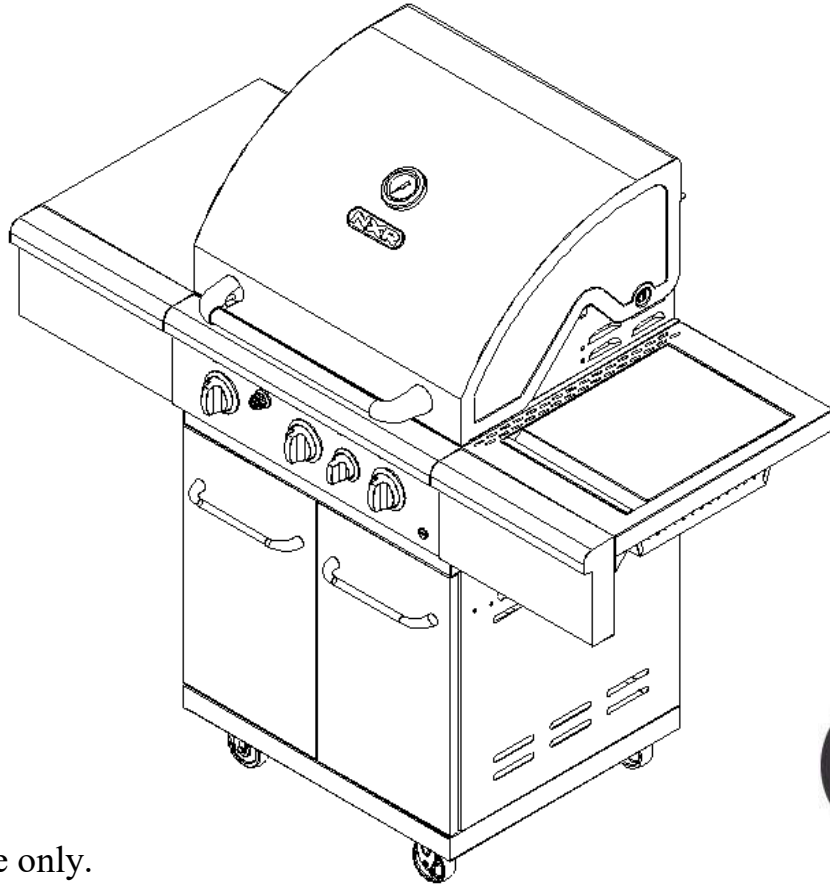

Warning:

For outdoor use only.

This instruction manual contains important information necessary for the proper assembly and safe use of the appliance.

Do not leave the appliance unattended. Keep young children and pets away.

Do not move the device during use.

Not intended to be installed in or on boats and should never be used as a heater.

Close the valve of the gas cylinder after use.

FOR YOUR SAFETY

Do not store or use gasoline or other flammable vapors and liquids in the vicinity of this or any other appliance.

▲ Warning: Improper installation, adjustment, alteration, service or maintenance can cause property damage, injury or death. Read the installation, operating and maintenance instructions thoroughly before installing or servicing this equipment.

Questions, problems, and/or missing parts? Before returning to your retailer, please send an email to our customer service department: nxrcs@duro-global.com



If you prefer to speak to a live agent; call 1-888-909-8818

Monday-Friday 9 AM-5 PM PST;

Languages Spoken: English, Spanish, French.

Thank you for purchasing your NXR outdoor grill.

We appreciate your business and we recommend that you read this entire owner's manual before operating your new appliance for the first time. Take a look at our safety instructions prior to use.

This manual contains instructions on how to properly install and set up your new grill, as well as insights into great features that our product offers. Please keep this manual for future reference.

Thank you,

Duro Corporation Inc.

TABEL OF CONTENTS

Precautions	4-7
Maintenance	8-10
Liquid Propane Gas Exploded View	11
Liquid Propane Gas Parts List	12-14
Assembly Instruction	15-23
Use and Care Instruction	24
Trouble Shooting	15-26
Limited Warranty	27-28

PRECAUTIONS

When using the grill, do not touch the grill rack, burner grate or immediate surroundings become extremely hot and could cause burns. Use only dry potholders. Moist or damp potholders on hot surfaces may cause burns from steam. Do not use a towel or bulky cloth in place of potholders. Do not let potholders touch hot portions of the grill rack.

Grease is flammable. Let hot grease cool before attempting to handle it. Avoid excess grease deposits collect in the grease tray at the bottom of the grill's firebox. Clean often.

For proper lighting and performance of the burners keep the burner ports clean. It is necessary to clean them periodically for optimum performance. The burners will only operate in one position and must be mounted correctly for safe operation.

Clean the grill with caution. Avoid steam burns; do not use a wet sponge or cloth to clean. Be sure all grill controls are turned off and the grill is cool before using any type of aerosol cleaner on or around the grill. The chemical that produces the spraying action could, in the presence of heat, ignite, or cause metal parts to corrode.

Do not use the grill for cooking excessively fatty meats or products, which promote flare-ups. Do not operate the grill under unprotected combustible construction. Use only in well ventilated areas. Do not use in buildings, garages, sheds, breezeways or other such enclosed areas. THIS UNIT IS FOR OUTDOOR USE ONLY.

CAUTION: BEWARE OF BACKFLASH

- CAUTION: Spiders and small insects occasionally spin webs or make nests in the grill burner tubes during transit and warehousing. These webs can lead to gas flow obstruction, which could result in a fire in and around burner tubes. This type of fire is known as "BACKFLASH" and can cause serious damage to your grill and create an unsafe operating condition for the user.

Although an obstructed burner tube is not the only cause of "BACKFLASH", it is the most common cause. To reduce the chance of "BACKFLASH", you must clean the burner tubes before assembling your grill, and at least once a month in late summer or early fall when spiders are most active. Also perform this burner tube cleaning procedure if your grill has not been used for an extended period of time. A clogged tube can lead to a fire beneath the grill.

SAFETY INFORMATION

- Never operate this BBQ without a pressure regulator.
- The following supply pressures are a guide only.
- Supply pressures stated in TECHNICAL DESCRIPTION as guidance.



Model - DURO	780-0862SB				
Product name	Gas Grill				
Nominal Heat Input (Hs)	G30:14.87KW(1352g/h)				
Countries Code	CZ,DE,DK,FI,GB,IT,NL,N O,RO,SE,SI	BE,CH,CZ,ES,FR,GB,IE,IT, PT,SI		PL	AT,CH,CZ,DE
Appliance's Category	I3 B/P(30)	I3+ (28-30 / 37)		I3 B/P(37)	I3 B/P(50)
Gas Type	Butane/Propane or their Mixtures	Butane	Propane	Butane/Propane or their Mixtures	Butane/Propane or their Mixtures
Gas Pressure (mbar)	30	28~30	37	37	50
	<input type="checkbox"/>	<input checked="" type="checkbox"/>		<input type="checkbox"/>	<input type="checkbox"/>
Injector Size	Main burner:0.94mm				
	Searing Burner: 1.02 mm				

THE MARKING OF INJECTORS

The marking of injectors as diagram is the injector size.

REGULATOR AND HOSE ASSEMBLY:

- Must be suitable for Liquid Propane Gas (LPG).
- Must withstand the above-mentioned pressures.
- Use 30mbar regulator for the gas category I3B/P(30).
- Use 30mbar regulator for butane gas under the category I3+(28-30/37).
- Use 37mbar regulator for propane gas under the category I3+(28-30/37).
- Use 50mbar regulator for propane gas under the category I3B/P(50).
- The length for hose may not exceed 1.5 meters.
- Use an appropriate Jubilee clip or twin-eared fastener to connect the hose to the BBQ adaptor to secure the hose/regulator connection.

BUTANE OR PROPANE OR LPG GAS MIXTURES

There are three different types of gas which can be used for your gas BBQ. It is important for you to use the correct regulator to match the types of gas you buy.

LOCATION OF YOUR BBQ

- This barbecue must only to be used outdoors.
- Do not use this barbecue inside recreational vehicles.
- Do not obstruct the flow or combustion and ventilation air around the BBQ.
- Use grill at least 60cm / 24in away from any wall or surface. Maintain 3m. clearance far away to the objects which can catch fire or sources of ignition, such as pilot lights on water heaters, live electrical appliances, etc.

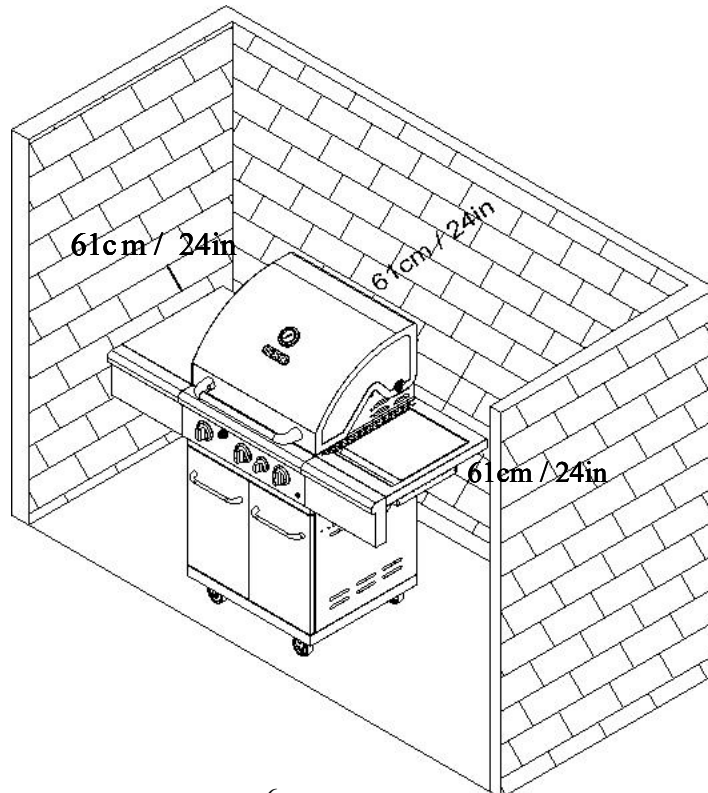

CHECKING FOR GAS LEAKS

NOTE: Never test leaks with an open flame.

If you smell gas, do not attempt to light the BBQ, just close the valve of the gas tank, and extinguish naked flames.

Check gas leaks prior to first use, and at the beginning of each new season (or, whenever gas tank is changed).

1. Prepare some soapy solution.
2. Turn burner control(s) to “OFF”, and then turn on gas at the source.
3. Apply the soap solution to all gas connections. Bubbles will appear in the soap solution if connections are not properly sealed. Tighten or repair if necessary.
4. If you encounter a problem of gas leak you can't repair, turn off the gas tank valve, disconnect hose and consult your BBQ dealer or supplier.

Flame Characteristics

Check for proper burner flame characteristics. Burner flames should be blue and stable with no yellow tips, excessive noise, or lifting. The following steps should be followed for correcting the flame characteristics:

1. Turn the control knobs and Cylinder valves “OFF”.
2. Allow the grill and burners to cool.
3. If the flame is yellow (not enough air), turn the control knob counterclockwise.
4. If the flame is noisy or lifting away from the burner (too much air), turn the control knob clockwise.
5. If these adjustments do not correct the problem, contact related customer service.

Do not store or use gasoline, liquid propane cylinder or other flammable vapours and liquids in the vicinity of this appliance.

The installation and service of your appliance must be performed by a qualified installer, an approved service agency or the gas supplier.

Gas appliances can cause minor exposure to four of these substances, namely benzene, carbon monoxide, formaldehyde and soot, caused primarily by the incomplete combustion of natural gas fuel. When operating your grill on liquid propane, the flames from the burners should be blue in color. In addition, the flames should be stable, free of yellow tipping, excessive noise and lifting. However, this yellow tipping should be restricted to the primary flame kernels only. Properly adjusted burners, indicated by a bluish rather than a yellow flame, will minimize incomplete combustion. Exposure to those substances can be minimized by venting with an open window or use of a ventilation fan or hood.

MAINTENANCE

BACKFLASH

- Turn off gas tank valve and turn the burner control knob(s) to “OFF”. Wait until the firebox is cool enough, and then clean burner tubes and burner ports.

CLEANING THE GRILL PLATES

- Close the gas cylinder valve.
- Wait the grill plates to cool down before washing them in the warm soapy solution through using a moist dish cloth, nylon scourer or brass wire brush.

CLEANING THE FLAME TAMER

- Periodically wash the flame tamer in the warm soapy solution. Use a brass wire brush to remove stubborn caked or cooking residue if necessary. Make sure they are dry thoroughly before re-installing them onto the BBQ body.

CLEANING THE GREASE RECEPTACLE

- Allow the grease tray or grease box to cool down before emptying and washing them in the liquid detergent.

STORAGE OF APPLIANCE

If the appliance is stored indoors please ensure it is cool. Storage of appliance indoors is only permitted when the cylinder is disconnected and removed from the appliance and cylinder is stored outside in the well-ventilated area, out of reach of children. If the appliance won't be used for a period of time, it should be stored in its original packaging and in the dry and dust free environment.

ANNUAL CLEANING OF BBQ

Cleaning the grill and hot plate after each use will keep it ready for instant use. Once a year, clean the entire BBQ thoroughly.

INTERIOR

- Turn the burner controls to “OFF” position, close the gas cylinder valve and disconnect gas supply.
- Detach the hose/regulator assembly from BBQ.
- Remove and clean the cooking plates, flame tamers and burners.
- Cover gas valve orifices with aluminum foil.

FIRST USE / USE AFTER LONG PERIODS - BEGINNING OF SEASON

- Read Safety, Lighting and Operating Instructions carefully.
- Check gas valve orifices, burner tubes and burner ports for any obstruction.
- Check that the burner tube is properly located over the valve orifice.
- Check if the cylinder is filled.
- Set burner controls to “OFF” and connect the gas supply.
- Check gas leaks using soapy water solution.
- Open the hood before lighting.

TO MATCH LIGHT THE GRILL:

If the burner will not light after several attempts then the burner can be lit by match.

If you've just attempted to light the burner with the igniter, allow 5 minutes for any accumulated gas to dissipate. Keep your face and hands as far away from the grill as possible.

Insert a lit extended match or lighter through the cooking grids to the burner. Press the control knob and rotate left to the HI setting, continue to press the knob until the burner ignites.

Burner should light immediately. If the burner does not light in 4 seconds, turn the knob off, wait 5 minutes and try again.

BURN-OFF PROCEDURE

Before cooking on your BBQ for the first time, burn-off any residual oils or foreign matter from grill/plate/pan.

- With hood fully open, operate burners at “HI” for approximately 10-15 minutes.
- Turn off, allowing to cool, wash with soap suds and scrubbing brush. Wipe clean with cloth.

COOKING WITH HOOD DOWN

IMPORTANT: Never use all burners on “HI” when cooking with hood down.

- Only use burners as shown in the diagram when cooking with the hood down.
- Position the flame tamer, grill plate or cooking pan over centre burners. Close hood and adjust burners to “LO”.
- Always open the hood before lighting.
- Check progress periodically.

IF BBQ FAILS TO OPERATE PROPERLY

- Do not smoke while checking!
- Turn off the gas at source, turn burner control to “OFF”.
- Wait five minutes before trying again.
- Check gas supply / connections.
- Repeat lighting procedure and, if BBQ still fails to operate properly, turn off the gas at source, and turn the burner controls to “OFF”. Wait for BBQ to cool down and check the following:

a) Misalignment of burner tube(s) over orifice(s).

CORRECTION: Re-position burner tube to properly sit over orifice.

b) Obstruction in gas line.

CORRECTION: Remove hose from BBQ.

Open gas supply for one second to clear any obstruction from hose. Close off gas supply at source and reconnect hose to BBQ.

c) Blocked orifice

CORRECTION: Remove loose items from inside BBQ body. Remove burners by pulling cotter pin from beneath burner “foot” using a screwdriver or needle-nose pliers. Lift each burner away from gas valve orifice; clear any obstruction with a fine wire. Re-install burners over orifices and seat each burner “foot” into mounting bracket at the bottom of BBQ body. Re-install cotter pins and cooking components.

d) Misalignment of igniter on burner

CORRECTION: The tip of the electrode should be pointing towards the collector box. The distance between the spark electrode and the tip of the collector box should be 3-5 mm. Adjust if necessary by bending carefully.

If re-ignition is necessary while the BBQ is still hot, wait for at least five minutes before commencing to re-ignite. (This allows accumulated gas to clear).

If all checks/corrections have been made and BBQ still fails to operate properly, consult your BBQ dealer or gas appliance service person.

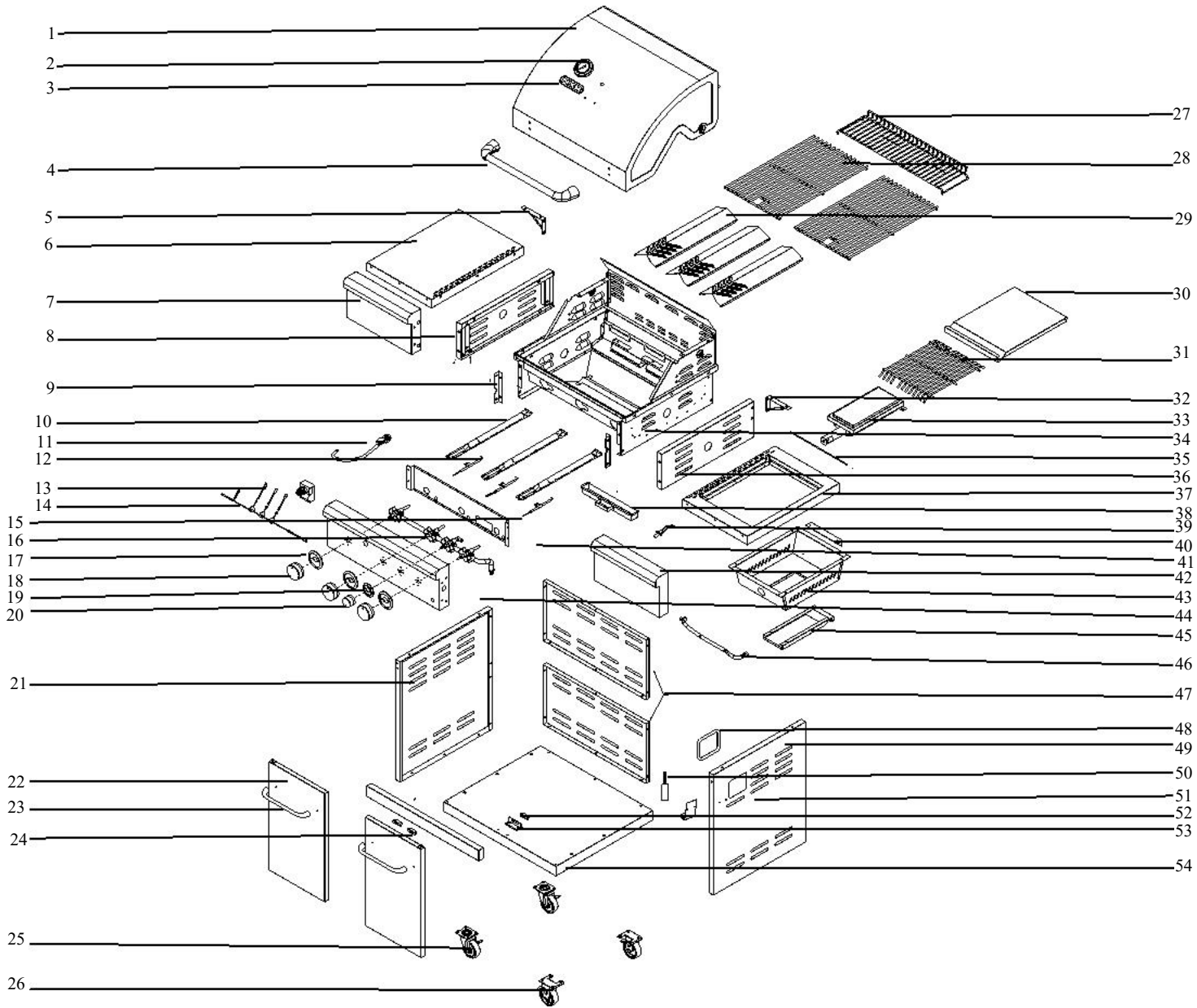

Liquid Propane Gas Exploded View



Liquid Propane Gas Parts list

Part No.	Part Nanme	Qty	Part No.	Part Nanme	Qty
1	Main lid	1	28	Cooking grates	2
2	Temperature gauge	1	29	Flame tamers	3
3	Logo	1	30	Side Burner Lid	1
4	Main Lid Handle	1	31	Side burner cooking grate	1
5	Side shelve support left	1	32	Side shelve support right	1
6	Side shelve left	1	33	Searing Burner	1
7	Control Panel left	1	34	Fire box	1
8	Cart division plate A	1	35	Side Burner Lid Hinge Rod	1
9	Control panel fixed plate	1	36	Cart division plate B	1
10	Main burners	3	37	Side shelve right	1
11	LP regulator	1	38	Grease tray	1
12	Main Burner ignitor Wire A	1	39	Side Burner ignitor	1
13	Electric ignitor	1	40	Side Burner support	1
14	LED Lamp cord& LED light	1	41	Control panel heat shield	1
15	Main Burner ignitor Wire B	1	42	Control Panel right	1
16	Gas supply manifold	1	43	Side burner base with orifice	1
17	Control knobbezel	3	44	Control Panel	1
18	Control knob	3	45	Side Burner Grease tray	1
19	Side Burner knob knobbezel	1	46	Corrugated pipe	1
20	Side Burner knob	1	47	Cart rear panel	2
21	Cart side panel left	1	48	Glues tape	1
22	Door	2	49	Cart side panel right	1
23	Handle	2	50	Led Battery box	1
24	Cart Cross beam	1	51	Led Battery box fixed plate	1
25	3”Caster swivel	2	52	Magnet	1
26	3”Caster	2	53	Cart bottom panel magnet support	1
27	Warming rack	1	54	Cart bottom panel	1

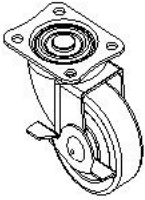
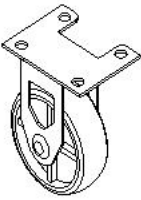
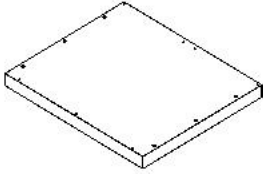
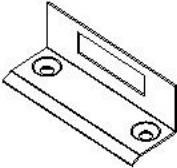
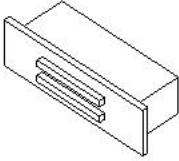
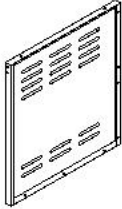
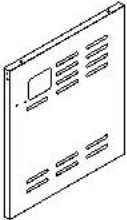
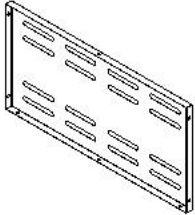
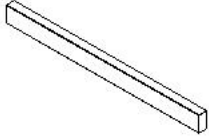
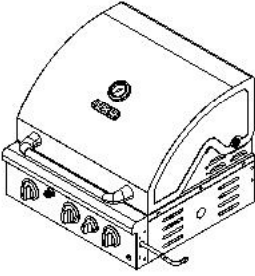
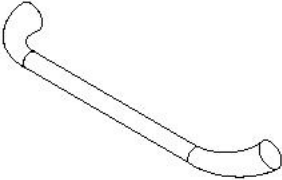
Package contents list

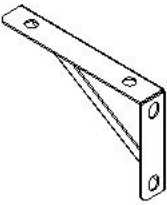
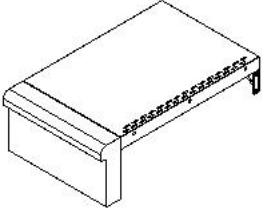
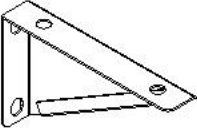
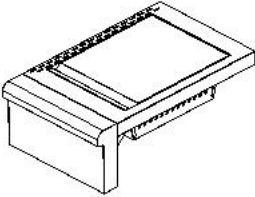
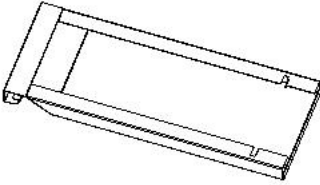
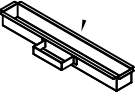
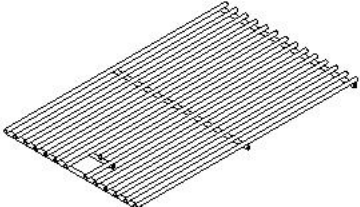
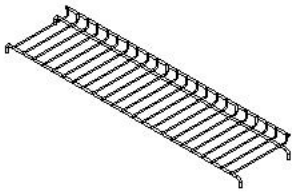
<p>A.3" Caster swivel -----2pcs.</p> 	<p>B.3" Caster ---- 2pcs.</p> 	<p>C.Cart bottom panel -----1pc.</p> 
<p>D. Cart bottom panel magnet support----1pc.</p> 	<p>E. Magnet -----3pcs.</p> 	<p>F. Cart side panel left -----1pc.</p> 
<p>G. Cart side panel right ----1pc.</p> 	<p>H. Cart rear panel -----2pcs.</p> 	<p>I. Cart cross beam -----1pc.</p> 
<p>J. Fire box and Lid -----1pc.</p> 	<p>K. Door handle --- 2pcs.</p> 	<p>L. Door left--- 1pc .</p> 
<p>M. Door right --- 1pc.</p> 	<p>N. Side shelve support left --- 1pc</p> 	<p>O. Side shelve left --- 1pc</p> 
<p>P. Side shelve right --- 1pc</p> 	<p>Q. Side burner --- 1pc.</p> 	<p>R. Side burner grease tray ---1pc.</p> 
<p>S. Grease box -----1pc.</p> 	<p>T. Cooking grates ---2pcs.</p> 	<p>U. Warming rack---1pc.</p> 

V. Flame tamers --3pcs.

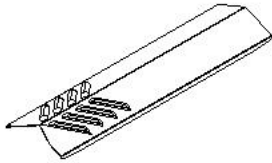

REF#	Description	QTY
AA	5/32-in. x 12-mm Screw with washer	16pcs.
BB	5/32-in. x 10mm Screw	2pcs.
CC	5/32-in. Washer	12pcs.
DD	1/4-in. x 12-mm Screw	44pcs.
EE	1/4-in. Flat screw	26pcs.
FF	1/4-in. Sparing washer	26pcs.
GG	5/32-in. x 12-mm Screw	4pcs.

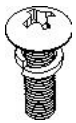

AA



BB



CC



DD



EE



FF



GG

ASSEMBLY INSTRUCTIONS

1. Fix the casters **NOTE: We recommend at least 2 people to assemble grill.** **Warning: Make sure the casters are tightene.**

Warning: Make sure that all casters have been tightened before unfold the legs of cart.

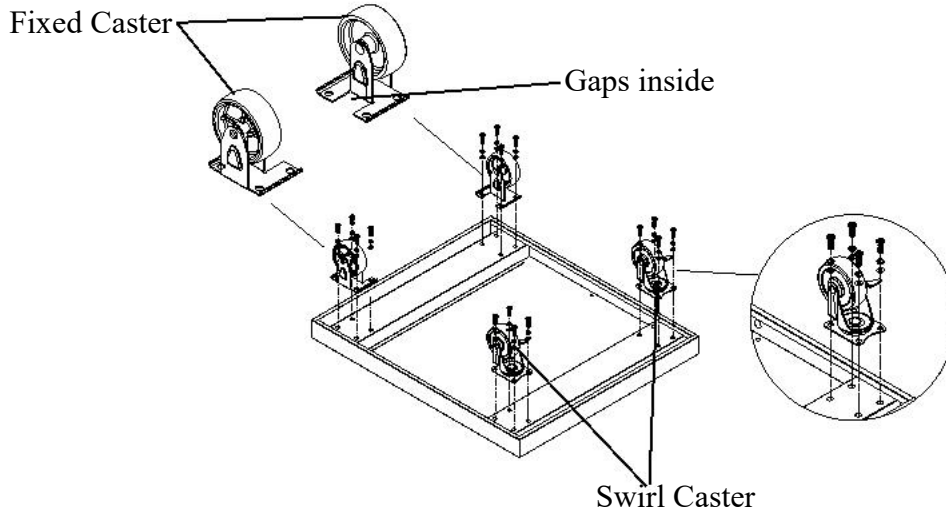

DD:16pcs
EE:16pcs
FF:16pcs

2. Assemble the door magnet seat

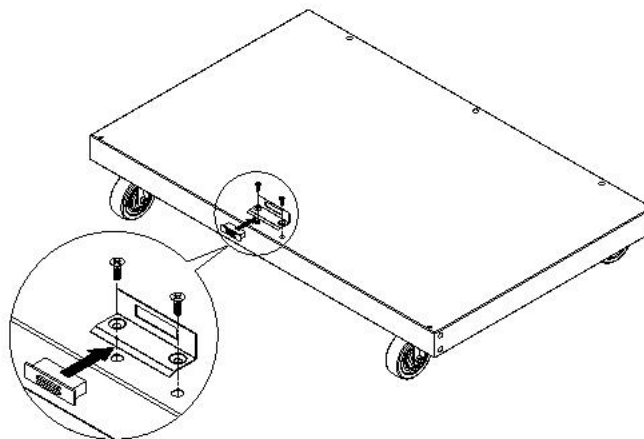

BB:2pcs

3. Install the cart side panel

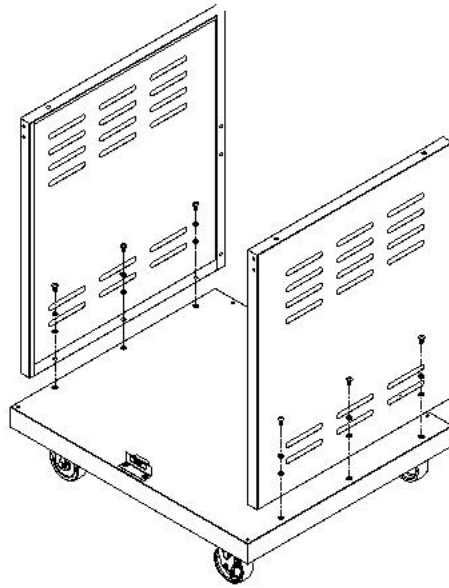

DD 6PCS
EE 6PCS
FF 6PCS

4. Install the cart rear panel

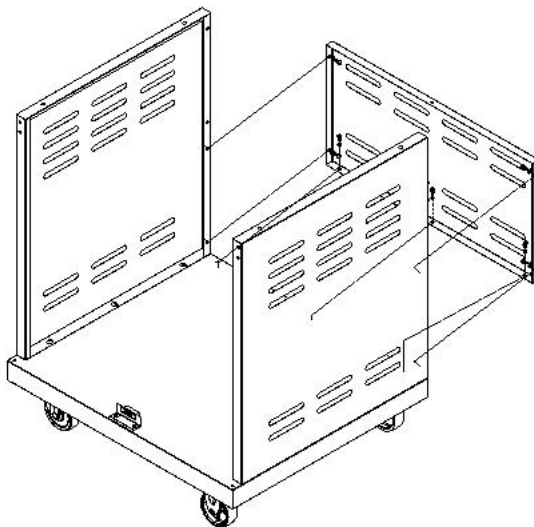

AA 7PCS
CC 7PCS

5. Install the cart rear panel

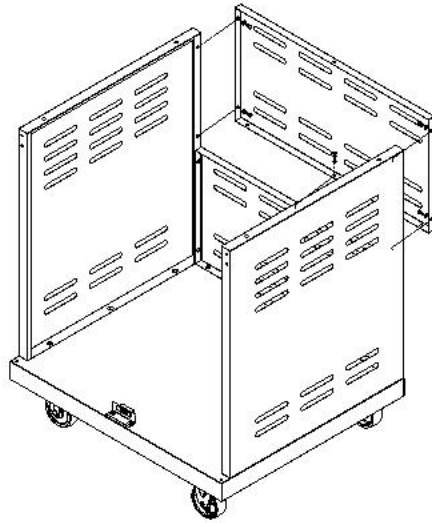

AA:5pcs
CC:5pcs

6. Install the beam

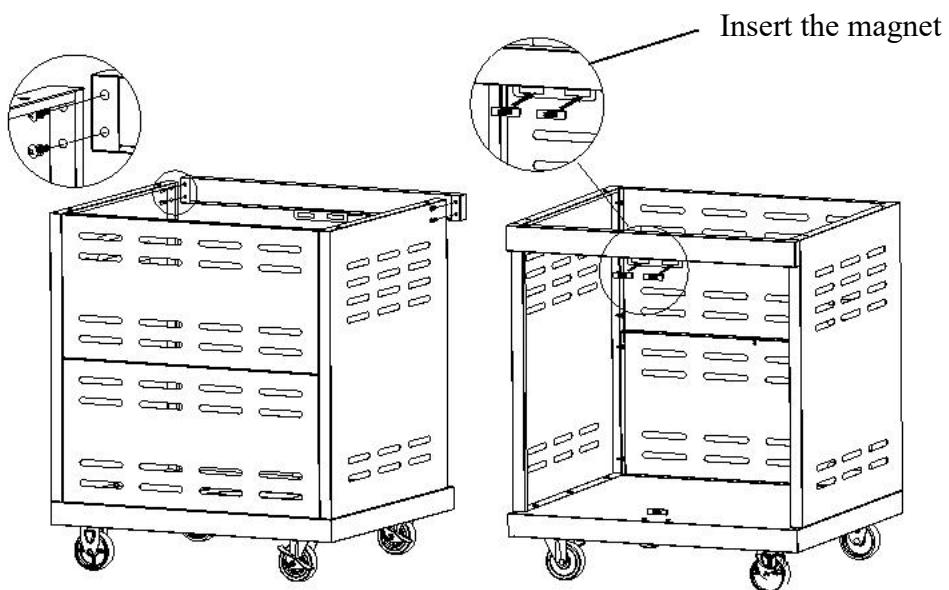

AA:4pcs

7. Install the fire box

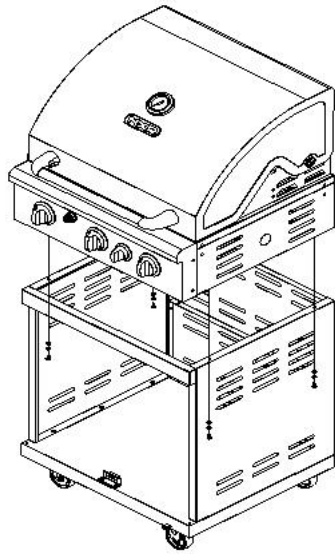

DD:4pcs
EE:4pcs
FF:4pcs

8. Install the door handle

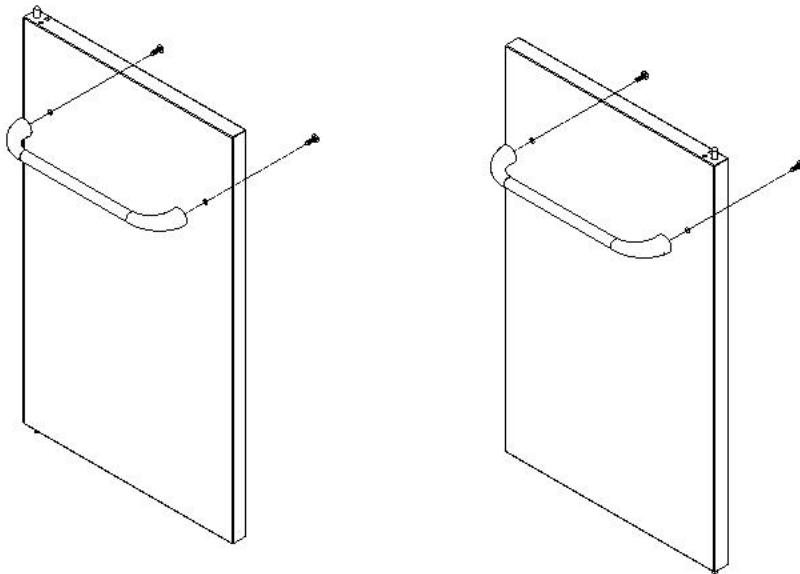

GG:4pcs

9. Install the door

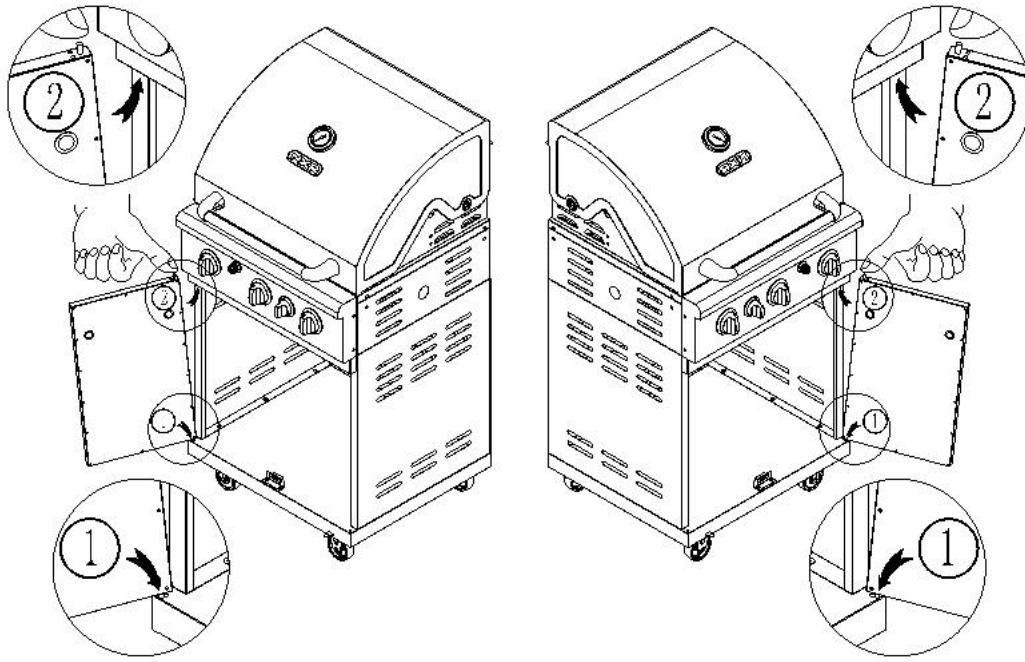

10. Install the side burner

DD 9PCS

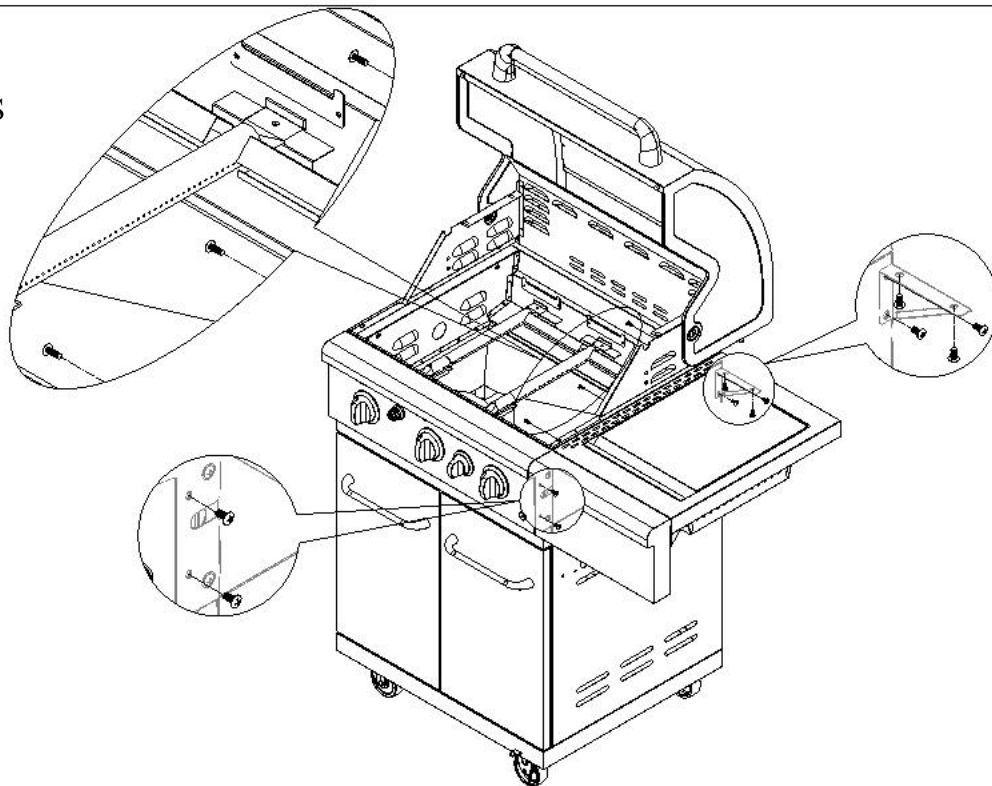

11. Install the side searing burner gas valve and cooking grill

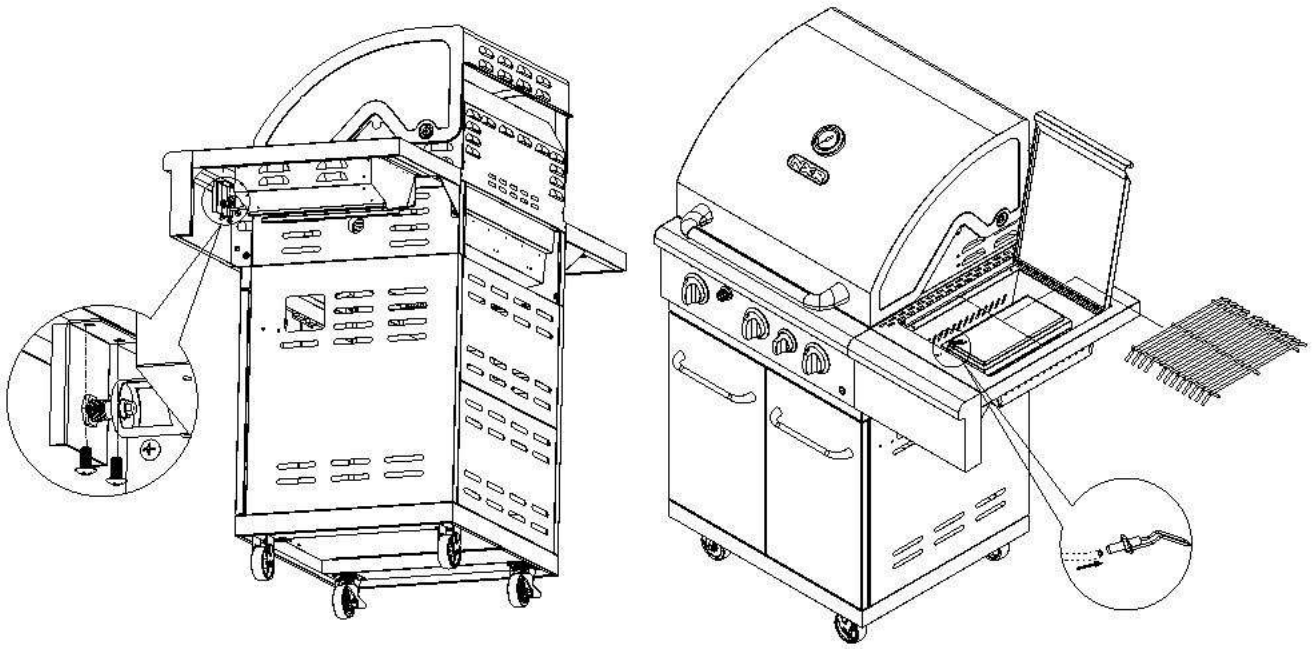

12. Install the side shelf left

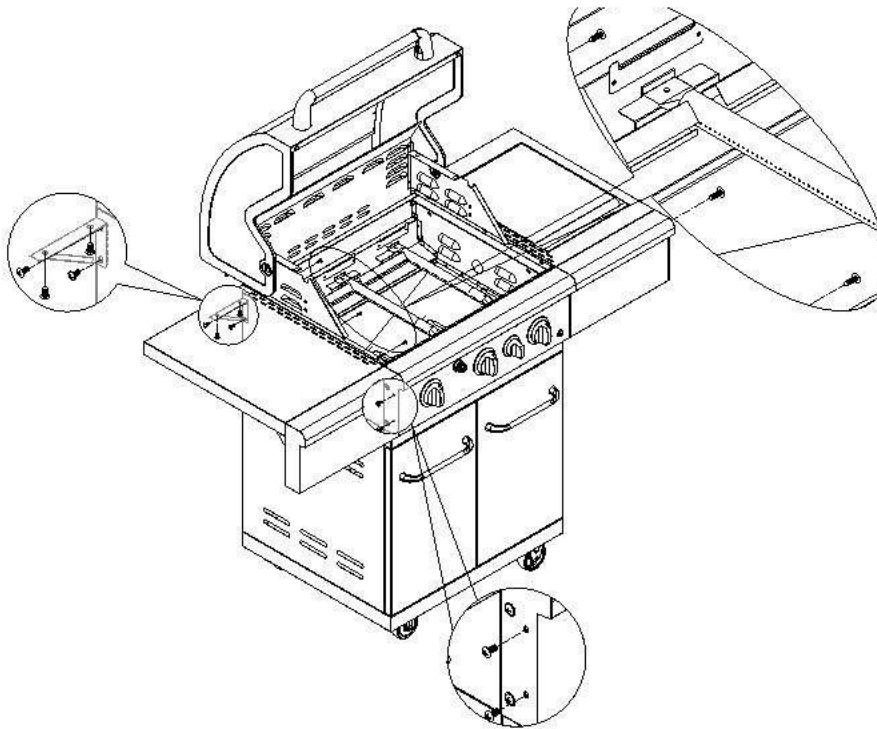

13. Install the batteries

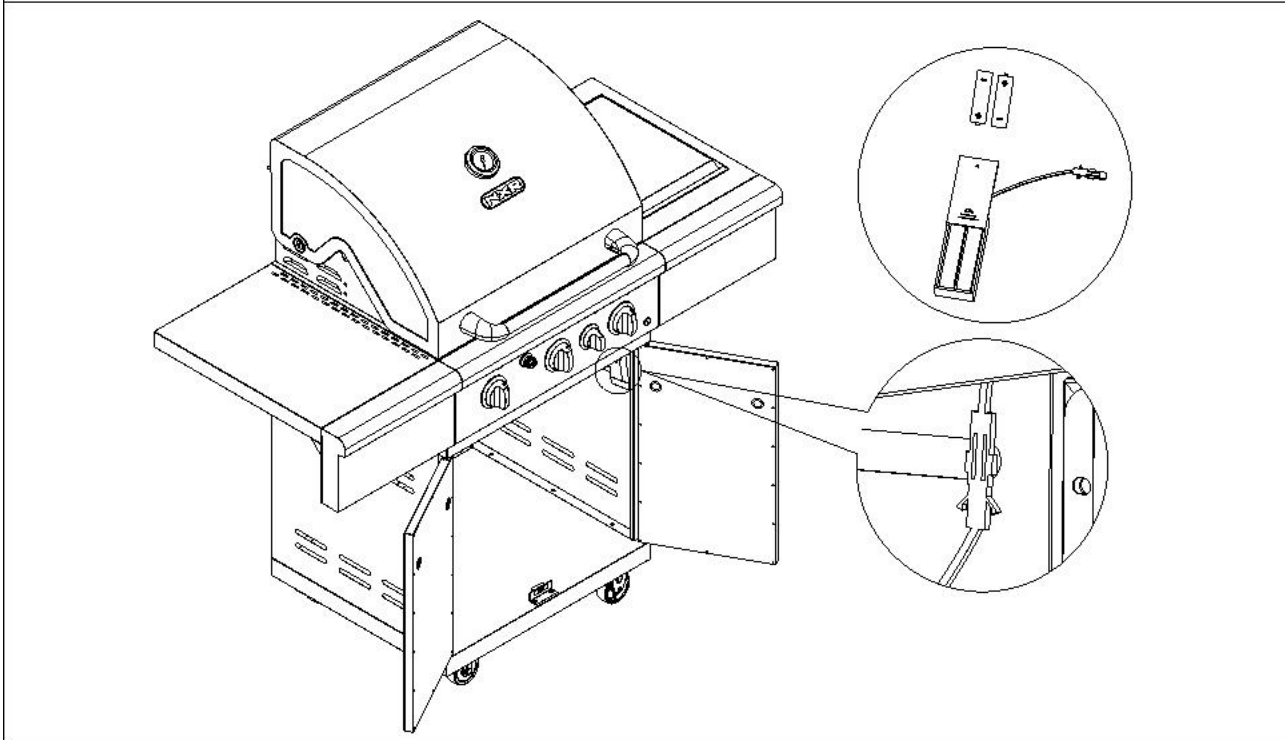

14. Insert the grease box

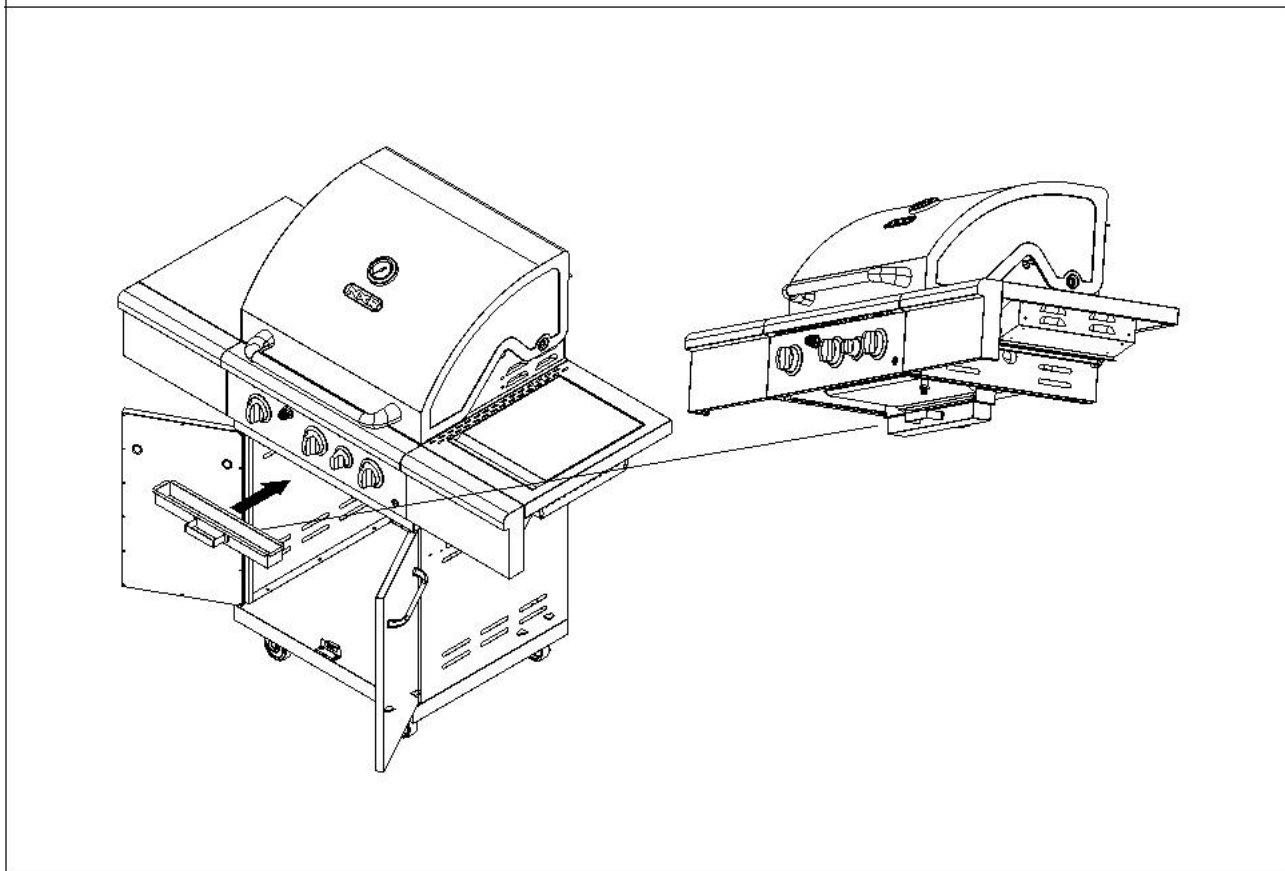

15. Insert the side burner grease tray

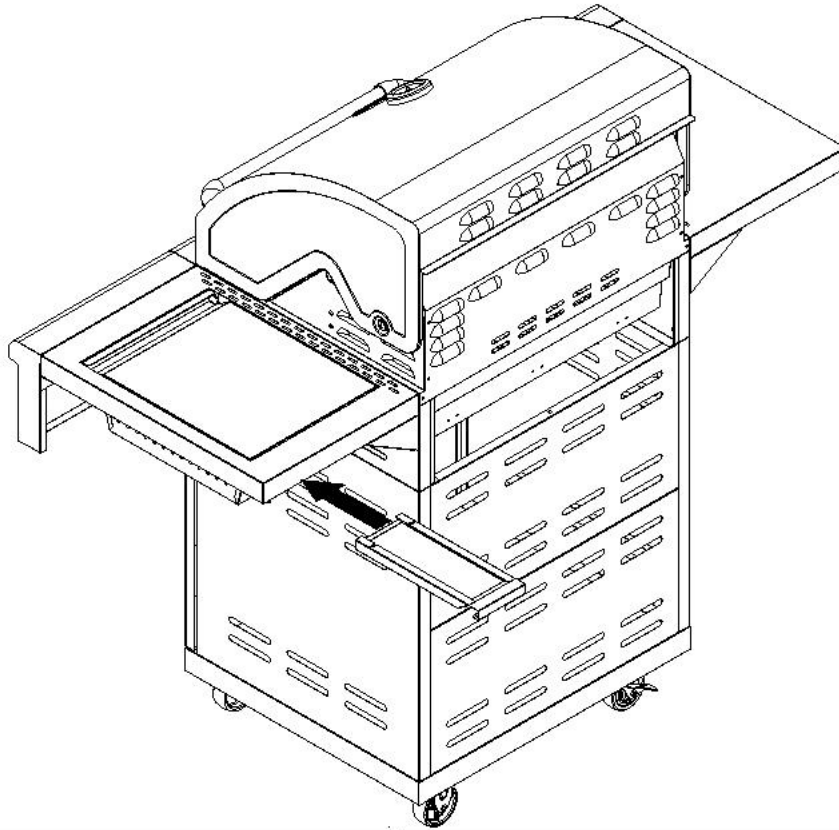

16. Place the flame tamer, cooking grid and warming rack

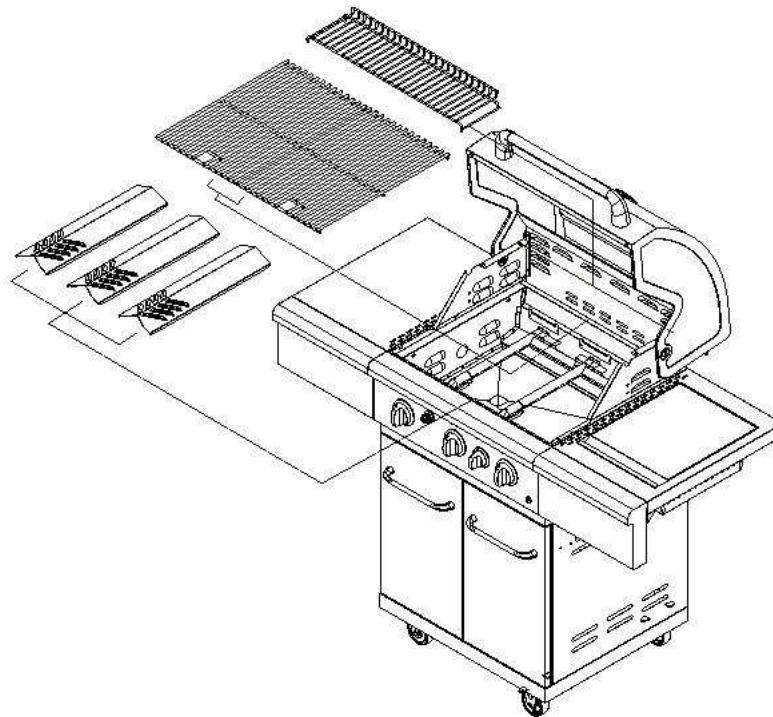

17. Install the battery

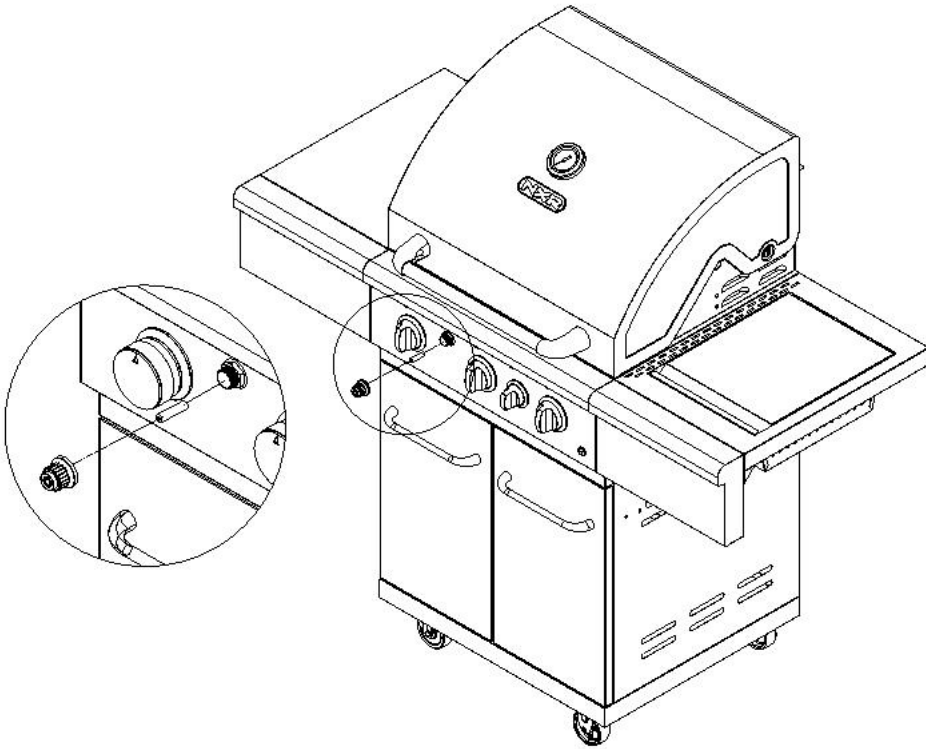

USE AND CARE INSTRUCTIONS

Grilling requires high heat for searing and proper browning. Most foods are cooked at the “HI” heat setting for the entire cooking time. However, when grilling large pieces of meat or poultry, it may be necessary to turn the heat to a lower setting after the initial browning. This cooks the food through without burning the outside. Foods cooked for a long time or foods basted with a sugary marinade may need a lower heat setting near the end of the cooking time.

NOTE: This stainless steel grill is designed to grill efficiently without the use of lava rocks or briquettes of any kind. Heat is radiated by the stainless steel flame tamers positioned above each burner.

NOTE: The hot grill sears the food, sealing in the juices. The longer the preheat, the faster the meat browns and the darker the grill marks.

DO NOT LEAVE THE GRILL UNATTENDED WHILE COOKING.

CAUTION: PLEASE TAKE OFF THE WARMING RACK WHEN USING THE ROTIS BURNER. THE HIGH HEAT COMING FROM THE ROTIS BURNER MAY CAUSE THE WARMING RACK TO BEND.

STAINLESS STEEL

There are many different stainless steel cleaners available. Always use the mildest cleaning procedure first, scrubbing in the direction of the grain. Specks of grease can gather on the surfaces of the stainless steel and bake on to the surface and give the appearance of rust. For removal use a mild abrasive pad in conjunction with a stainless steel cleaner.

GRILL GRATE

The easiest way to clean the grill is immediately after cooking is completed and after turning off the flame. Wear a barbeque mitt to protect your hand from the heat and steam. Dip a brass bristle barbeque brush in water and scrub the hot grill. Dip the brush frequently in the bowl of water. Steam, created as water contacts the hot grill, assists the cleaning process by softening any food particles. If the grill is allowed to cool before cleaning, cleaning will be more difficult.

MAIN GRILL BURNER CLEANING

Ensure the gas supply is off and the knobs are in the “OFF” position. Make sure the grill is cool. Clean the exterior of the burner with a wire brush. Remove stubborn scale with a metal scraper. Clear any clogged ports with a straightened paper clip. Never use a wooden toothpick as it may break off and clog the port. Please note if insects or other obstructions are blocking the flow of gas through the burner, and if so please send email to our customer service department: nxrcs@duro-global.com.

GREASE TRAY CLEANING:

The grease tray should be emptied and wiped down periodically and washed with a mild detergent and warm water solution. A small amount of sand may be placed in bottom of grease tray to absorb the grease. Check the grease tray frequently, do not allow excess grease to accumulate and overflow out of the grease tray.

BURNER CLEANING:

1. Turn off the gas supply, and make sure all the knobs are in the “OFF” position.
2. Wait for the grill to cool.
3. Clean the exterior of the burner with a wire brush. Use a metal scrapper to stubborn stains.
4. Clear clogged port with a straightened paper clip. Never use a wooden toothpick as it may break off and clog the port.
5. If inserts or other obstructions are blocking the flow of gas through the burner, please send email to our customer service department: nxrcs@duro-global.com.

Trouble Shooting

WHEN TO LOOK FOR SPIDERS

You should inspect the burners at least once a year or immediately after any of the following conditions occur:

1. The smell of gas in conjunction with the burner flames appearing yellow.
2. The grill does not reach temperature.
3. The grill heats unevenly.
4. The burners make popping noises.

PREHEATING: The grill lid should be in a closed position during the preheat time period. It is necessary to preheat the grill before cooking certain foods, depending on the type of food and the cooking temperature. Food that requires a high cooking temperature needs a pre-heat period of five minutes; food that requires a lower cooking temperature needs only a period of two to three minutes.

COOKING TEMPERATURES

High setting: Use this setting for fast warm-up, for searing steaks and chops, and grilling.

Low setting: Use this setting for all roasting, baking, and when cooking very lean cuts such as fish. These temperatures vary with the outside temperature and the amount of wind.

Cooking with indirect heat: You can cook poultry and large cuts of meat slowly to perfection on one side of the grill by indirect heat from the burner on the other side. Heat from the lighted burner circulates gently throughout the grill, cooking the meat or poultry without any direct flame touching it. This method greatly reduces flare-ups when cooking extra fatty cuts, because there is no direct flame to light the fats and juices that drip down during cooking.

CAUTION: If burners go out during operation, close gas supply at source, and turn all gas valves off. Open lid and wait five minutes before attempting to re-light (this allows accumulated gas fumes to clear).

CAUTION: Should a grease fire occur, close gas supply at source, turn off all burners and leave lid closed until fire is out.

CAUTION: DO NOT attempt to disconnect any gas fitting while your grill is in operation. As with all appliances, proper care and maintenance will keep them in top operating condition and prolong their life. Your gas grill is no exception.

PROBLEM	PROBLEM SOLUTION
Full size cover does not fit the grill.	<ul style="list-style-type: none"> • Cover may be incorrect for your grill. It may be a tight fit. Ensure the cover is the correct length for your grill. Measure it left to right. Compare to the grill's measurement. • Compare the location and size of the hood portion of the cover to your grill. • Spread the cover and allow it to relax, preferably in warm sunlight or in a warm room. • For grill with a side shelf bunch the cover like a sock, put on left to right.
Grill only heats to 200°C - 350°C (392°F - 662°F).	<ul style="list-style-type: none"> • Check to see if the fuel hose is bent or kinked. • Make sure the grill area is clear of dust. • Make sure the burner and orifices are clean. • Check for spiders and insects. • The regulator has a safety device that restricts the flow of gas in the event of a leak. This safety device can be triggered without a gas leak. To reset the safety device, turn off all burners and close the LP tank valve. Disconnect the regulator from the LP tank and wait one minute. Reconnect the regulator to the LP tank and slowly open the LP tank valve until the valve is fully open. Light all burners and observe the temperature.
Grill takes a long time to preheat.	<ul style="list-style-type: none"> • Normal preheat 250°C - 350°C (482°F - 662°F), takes about 10-15 minutes. Cold weather and wind may affect your preheat time. • If you are using volcanic rock or briquettes they can increase the preheat time and maximum temperature.
Burner flames are not light blue.	<ul style="list-style-type: none"> • Too much or not enough air for the flame. • Elevation is the principal cause, however cold weather can affect the mixture. Burner adjustment may be required. • Grill is in a windy location.

LIMITED WARRANTY

DURO warrants to the original consumer-purchaser only that this product (Model#780-0862SB) shall be free from defects in workmanship and materials after correct assembly and under normal and reasonable home use for the periods indicated below beginning on the date of purchase. The manufacturer reserves the right to require photographic evidence of damage, or that defective parts to be returned, postage and or freight Pre-paid by the consumer, for review and examination.

Stainless steel tube burners: 3 years warranty.

Flame tamers: 2 years LIMITED warranty; does not cover dropping, chipping, scratching, or surface damage.

Cooking grids: 2 Years LIMITED warranty; does not cover dropping, chipping, scratching, or surface damage.

All other parts: 1 Years LIMITED warranty (Includes, but not limited to, valves, frame, housing, cart, control panel, igniter, regulator, hoses); does not cover chipping, scratching, cracking surface corrosion, scratches or rust.

Upon consumer supplying proof of purchase as provided herein, Manufacturer will repair or replace the parts which are proven defective during the applicable warranty period. Parts required to complete such repair or replacement shall be free of charge to you except for shipping costs, as long as the purchaser is within the warranty period from the original date of purchase. The original consumer-purchaser will be responsible for all shipping charges of parts replaced under the terms of this limited warranty. This limited warranty is applicable in the United States only, is only available to the original owner of the product and is not transferable.

Manufacturer requires reasonable proof of your date of purchase. Therefore, you should retain your sales receipt and / or invoice. If the unit was received as a gift, please ask the gift-giver to send in the receipt on your behalf, to the below address. Defective or missing parts subject to this limited warranty will not be replaced without registration or proof of purchase. This limited warranty applies to the functionality of the product ONLY and does not cover cosmetic issues such as scratches, dents, corrosion or discoloring by heat, abrasive and chemical cleaners or any tools used in the assembly or installation of the appliance, surface rust, or the discoloration of stainless steel surfaces. Surface rust, corrosion, or powder paint chipping on metal parts that does not affect the structural integrity of the product is not considered a defect in workmanship or material and is not covered by this warranty. This limited warranty will not reimburse you for the cost of any inconvenience, food, personal injury or property damage. If an original replacement part is not available, a comparable replacement part will be sent. You will be responsible for all shipping charges of parts replaced under the terms of this limited warranty.

AUSTRALIA : Our goods come with guarantees that cannot be excluded under the Australian Consumer Law. You are entitled to a replacement or refund for a major failure and for compensation for any other reasonable foreseeable loss or damage. You are also entitled to have the goods repaired or replaced if the Goods fail to be of acceptable quality and the failure does not amount to a major failure.

LIMITED WARRANTY

ITEMS MANUFACTURER WILL NOT PAY FOR:

- Service calls to your home.
- Repairs when your product is used for other than normal, single-family house hold or residential use.
- Damage resulting from accident, alteration, misuse, lack of maintenance/ cleaning, abuse, fire, flood, acts of God, improper installation, and installation not in accordance with electrical or plumbing codes or use of products not approved by the manufacturer.
- Any food loss due to product failures.
- Replacement parts or repair labor costs for units operated outside the United States or Canada.
- Pick up and delivery of your product.
- Postage fees or photo processing fees for photos sent in as documentation.
- Repairs to parts or systems resulting from unauthorized modifications made to the product.
- The removal and/or re-installation of your product.
- Shipping cost, standard or expedited, for warranty / non warranty and replacement parts.

DISCLAIMER OF IMPLIED WARRANTIES; LIMITATION OF REMEDIES

Repair or replacement of defective parts is your exclusive remedy under the terms of this limited warranty. Manufacturer will not be responsible for any consequential or incidental damages arising from the breach of either this limited warranty or any applicable implied warranty, or for failure or damage resulting from acts of God, improper care and maintenance, grease fire, accident, alteration, replacement of parts by anyone other than Manufacturer, misuse, transportation, commercial use, abuse, hostile environments (inclement weather, acts of nature, animal tampering), improper installation or installation not in accordance with local codes or printed manufacturer instructions.

THIS LIMITED WARRANTY IS THE SOLE EXPRESS WARRANTY GIVEN BY THE MANUFACTURER. NO PRODUCT PERFORMANCE SPECIFICATION OR DESCRIPTION WHEREVER APPEARING IS WARRANTED BY MANUFACTURER EXCEPT TO THE EXTENT SET FORTH IN THIS LIMITED WARRANTY. ANY IMPLIED WARRANTY PROTECTION ARISING UNDER THE LAWS OF ANY STATE, INCLUDING IMPLIED WARRANTY OF MERCHANTABILITY OR FITNESS FOR A PARTICULAR PURPOSE OR USE, IS HEREBY LIMITED IN DURATION TO THE DURATION OF THIS LIMITED WARRANTY.

Neither dealers nor the retail establishment selling this product has any authority to make any additional warranties or to promise remedies in addition to or inconsistent with those stated above. Manufacturer's maximum liability, in any event, shall not exceed the documented purchase price of the product paid by the original consumer. This warranty only applies to units purchased from an authorized retailer and or re-seller.

NOTE: Some states do not allow an exclusion or limitation of incidental or consequential damages, so some of the above limitations or exclusions may not apply to you; this limited warranty gives you specific legal rights as set for herein. You may also have other rights which vary from state to state.

If you wish to obtain performance of any obligation under this limited warranty, you should write to:

DURO CORPORATION

17018 Evergreen Place

City of Industry, CA 91745

USA

All consumer returns, parts orders, general questions, and troubleshooting assistance can be acquired by calling our customer service department at 1-888-909-8818, 9:00 a.m. - 5p.m., PST, Monday-Friday. English, French, and Spanish representatives are available. Send email to: nxrcs@duro-global.com

Costco Wholesale UK Ltd / Costco Wholesale Iceland ehf.

Costco Online UK Ltd Kauptún 3-7, 210 Gardabaer

Hartspring Lane Iceland

Watford, Herts www.costco.is

WD25 8JS

United Kingdom

www.costco.co.uk